

PRODUCT DATA: Micro i.s. (5100 i.s.)

SAMPLE FOR MEASUREMENTS

Sample gas	Clean and dry at ambient temperature and free from particulates <0.6µm
Flow Control	AFCD maximizes measurement stability over the range – 1.5 – 6 ltr (0.05 – 0.2 ft ³)
Sample inlet connection	QuickConnect barb fitting – 5mm OD stub for 6.3mm (1/4") ID tube or adaptor to 1/4" NPT fitting option
Sample outlet connection	5mm OD stub (sample and bypass)
Inlet pressure	Pumped: 80kPa absolute (16.0psia) minimum / 110kPa absolute (16.0psia)

DEVICE SPECIFICATION

Size:

- 160mm (6.3") Width x 185mm (7.2") High x 140mm (7.2") Deep

Weight:

- 1.8kg – 2.3kg (4lbs – 5.1lbs)

Certifications:

- ATEX: Ex ia (Intrinsically Safe)
IIC T4 Ga (-10°C ≤ Ta ≤ +50°C)
(+14°F ≤ Ta ≤ +122°F)
- IEC: Ex ia (Intrinsically Safe)
IIC T4 Ga (-10°C ≤ Ta ≤ +50°C)
(+14°F ≤ Ta ≤ +122°F)
- FM: IS/1/ABCD/T4;
-10°C ≤ Ta ≤ +50°C: IP65 (Division 1)
- FM: IS/1/0/AEx ia/IIC/T4;
-10°C ≤ Ta ≤ +50°C: IP65 (Zone 0)
- CSA: IS/1/ABCD/T4;
-10°C ≤ Ta ≤ +50°C: IP65 (Division 1)
- CSA: IS/1/0/Ex ia/IIC/T4;
-10°C ≤ Ta ≤ +50°C: IP65 (Zone 0)
- CE marked and in compliance with ATEX, EMC and WEE Directives scope UL approved and CE marked 100-240V / 43-70Hz AC power supply

DEVICE SCHEMATIC

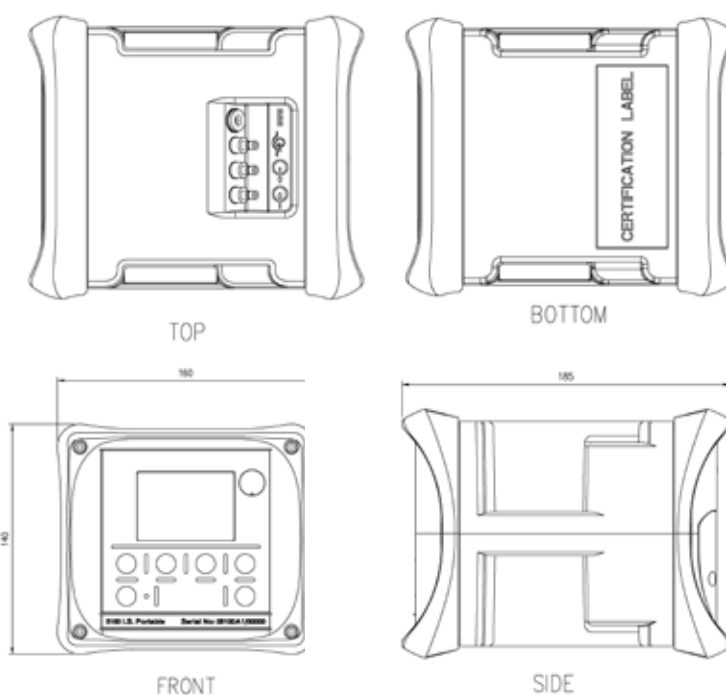

These analyzers are not intended for any form of use on humans and are not medical devices as described in the Medical Devices Directive 93/42EEC.

Please note: This document was updated in August 2014. While every effort has been made to ensure accuracy, no responsibility can be accepted for errors or omissions. Data may change, as well as legislation, and you are strongly advised to obtain copies of the most recently issued regulations, standards and guidelines. This document is not intended to form the basis of a contract.

PBMicro i.s. Rev.0 Date: 08/14

AMERICAS BUSINESS CENTER
Tel: +1 281 295 5800
Email: americas_sales@servomex.com

ASIA PACIFIC BUSINESS CENTRE
Tel: +86 (0)21 6489 7570
Email: asia_sales@servomex.com

EUROPEAN BUSINESS CENTRE
Tel: +31 (0) 79 330 1580
Email: europe_sales@servomex.com

LATIN AMERICA BUSINESS CENTER
Tel: +55 11 5188 8166
Email: brazil_sales@servomex.com

INDIA BUSINESS CENTER
Tel: +91 22 3934 2700
Email: MEI_sales@servomex.com

MIDDLE EAST BUSINESS CENTER
Tel: +971 6552 8073
Email: MEI_sales@servomex.com

SERVOMEX.COM

Servomex has a policy of constant product improvement and reserves the right to change specifications without notice.
© Servomex Group Limited. 2014. A Spectris company. All rights reserved.

SERVOMEX

SERVOFLEX

Micro i.s. (5100 i.s.)

HIGH PERFORMANCE OXYGEN, CARBON MONOXIDE AND CARBON DIOXIDE PORTABLE GAS ANALYSIS, DESIGNED FOR USE IN HAZARD RATED LOCATIONS INCLUDING ZONE 0/DIVISION 1



SERVOFLEX Micro i.s. (5100 i.s.)

Designed to meet the demands of the most dangerous environments, Micro i.s. delivers ultra-sensitive percentage measurements for oxygen, carbon monoxide and carbon dioxide. A tough, life-proof design and feature-rich performance ensures maximum operational flexibility.

Micro i.s. is Intrinsically Safe (i.s.) and is able to analyze both flammable and toxic samples. This intelligent design means that no purge is required prior to device use.

Micro i.s. also provides an intuitive user interface, the ability to store up to 200 measurements and up to 18 hours battery run time.

FLEXIBLE

- Intrinsically Safe (i.s.) design permits use in any hazard rated location including Zone 0/Division 1
- Gas analysis for O₂, CO or CO₂
- Pumped or non-pumped (AFCD) functions
- IP65 rating

EASY TO USE

- Intuitive, engineer-friendly interface and icons
- Stores up to 200 measurements for subsequent download
- Ergonomic design with carry strap

LOW COST OF OWNERSHIP

- Uses non-depleting sensor technologies that reduce ongoing maintenance costs
- Advanced Li-Ion rechargeable batteries as standard (up to 18 hour run time)

UNRIVALLED PERFORMANCE

- Uses industry-leading patented Paramagnetic and IR technologies and algorithms for ultra-sensitive and accurate measurements
- Manufactured by Servomex - over 60 years' experience innovating and pioneering gas analysis with thousands of units used in the field every year

BENCHMARK COMPLIANCE

- ATEX: Ex ia (Intrinsically Safe) IIC T4 Ga (-10°C ≤ Ta ≤ +50°C) (+14°F ≤ Ta ≤ +122°F)
- IEC: Ex ia (Intrinsically Safe) IIC T4 Ga (-10°C ≤ Ta ≤ +50°C) (+14°F ≤ Ta ≤ +122°F)
- FM: IS/1/ABCD/T4; -10°C ≤ Ta ≤ +50°C: IP65 (Division 1)
- FM: IS/0/AEx ia/IIC/T4; -10°C ≤ Ta ≤ +50°C: IP65 (Zone 0)
- CSA: IS/1/ABCD/T4; -10°C ≤ Ta ≤ +50°C: IP65 (Division 1)
- CSA: IS/0/Ex ia/IIC/T4; -10°C ≤ Ta ≤ +50°C: IP65 (Zone 0)

Learn more about the SERVOFLEX Micro i.s. (5100 i.s.)
VISIT SERVOMEX.COM



SERVOMEX.COM

PRODUCT OVERVIEW: Micro i.s. (5100 i.s.)

ENHANCED SAFETY FOR THE MOST DANGEROUS LOCATIONS

When you work in environments where potentially explosive atmospheres may be present, you need the most robust analytical solutions that enhance safety and provide efficient, engineer-friendly gas measurements.

In applications like catalytic regeneration, decoke cycle, combustion optimization and hazardous area process monitoring, i.s. certified solutions help reduce costs and improve efficiency. No matter what your application monitoring requirements are, you'll want a device that offers feature-rich performance, long battery runtime, low operational costs, simplified ongoing maintenance and ease of use. And we don't believe you should have to compromise.

A NO COMPROMISE SOLUTION

The Micro i.s. combines intuitive user interaction and an safety-enhanced i.s. design with ultra-sensitive, industry-leading O₂, CO and CO₂ monitoring capabilities, providing the ideal portable gas analysis solution for hazardous applications.

With flexible options including pumped and non-pumped formats and a range of features designed to further simplify sample testing, the Micro i.s. doesn't just meet requirements: it adapts perfectly to deliver the efficiency and usability your job demands.

WORKS AS HARD AS YOU DO

Optimized to deliver a tough and hard-working solution with maximized uptime, the Micro i.s. comes with high-grade, long-life Li-Ion rechargeable batteries as standard. An integrated digital LCD notepad also allows up to 200 measurements to be stored on the device, permitting you to work and test with maximized efficiency.

ALTERNATIVE PRODUCTS

The SERVOFLEX portable product range features a number of options designed to meet your application needs.

MiniMP (5200)



MiniMP combines high powered CO₂ and O₂ monitoring capabilities with ease of use and minimum maintenance requirements. (EN15267-3 MCERTs approved), providing a high performance solution suited to quality testing in safe areas.

MiniHD (5200)



Designed to withstand harsh conditions, this CO₂, CO and O₂ analysis unit has an IP65 rating, protective, durable overmoulding and leading edge detection capabilities for safe area locations.

KEY APPLICATIONS

- Hazardous area combustion optimization
- Natural gas processing
- Refineries – catalytic cracker regeneration
- HyCO applications
- Cracker decoke cycle on petrochemical plant
- Process monitoring
- Inerting applications



PRODUCT DATA: Micro i.s. (5100 i.s.)

OPTIONS	DESCRIPTION	SPECIFICATION
Rechargeable batteries	Advanced Lithium Ion (Li-Ion): Li-ion (O2) 5110 pumped	16.5 hours run time (50°C/122°F) 14.8 hours run time (20°C/68°F) 10.5 hours run time (-5°C /23°F) 9.7 hours run time (-10°C /14°F)
Rechargeable batteries	Advanced Lithium Ion (Li-Ion): Li-ion (IR) 5110 pumped	10.5 hours run time (50°C/122°F) 9.7 hours run time (20°C/68°F) 7.4 hours run time (-5°C /23°F) 7 hours run time (-10°C /14°F)
Rechargeable batteries	Advanced Lithium Ion (Li-Ion): Li-ion (O2) 5111 AFCD	18 hours run time (50°C/122°F) 18 hours run time (20°C/68°F)
Rechargeable batteries	Advanced Lithium Ion (Li-Ion): Li-ion (IR) 5111 AFCD	11.4 hours run time (50°C/122°F) 11.4 hours run time (20°C/68°F) 9 hours run time (-10°C /14°F)
Power supply*	Device charging is only permitted in a safe area	100-240V charger supplied as standard (device is not designed to operate from main power source)
Alarms*	Flexible, user-configurable options	Concentration alarms indicated by a LED, icon display and audible sounder

ACCESSORIES	DESCRIPTION	SPECIFICATION
QuickConnect barb fitting	Simplify connection of gases with QuickConnect	Zero and span gas, 1/4" NPT
Sampling probe	Facilitates simplified sample drawing for continuous flow rate	25cm with protective tip 180°C / 356°F max temp.) 100 cm untipped
Optional connector	Permits quick connection	1/8" NPT thread fitting
2 years spares pack	Two years hassle-free operation	5x filters, 1 filter O-ring
Carry case	Robust and life-proof case for added protection	Black finish, ergonomic design with strap
Transport case	For use in safe areas only	Keeps your device safe in an impact resistant case

MONITORING PERFORMANCE				
Sensor	O ₂	O ₂	CO	CO ₂
Technology	Paramagnetic	Paramagnetic	Infrared	Infrared
Variant	Standard (1 dp)	High Accuracy (2 dp)	-	-
Full scale and Min. output	0-100% 0-10% (min.)	0-100% 0-1% (min.)	0-5% CO	0-10%, 25%, 50%, 100% CO ₂
Cell construction	316 Stainless Steel	316 Stainless Steel	316 Stainless Steel	316 Stainless Steel
Accuracy (intrinsic error)	±0.1% O ₂	±0.05% O ₂	±2% FSR	±2% FSR
Zero drift/week	±0.4% O ₂	±0.2% O ₂	±4% FSR	±4% FSR
T90 in secs.	<15	<15	<15	<15
Operating Temp.	-10 to +50°C (14 to 122°F)	-10 to +50°C (14 to 122°F)	-10 to +50°C (14 to 122°F)	-10 to +50°C (14 to 122°F)

Please note: Samples in excess of 21% Oxygen should not be measured in hazardous area. We recommend a calibration of the analyser after each power up. Allow 1 hour warm up to meet performance specification. Please contact us for further information. *Standard feature

